

Read this instruction manual carefully before use.  
Keep this manual in hand while you use this product.

**Warranty Period : 1 year**

Minoura offers 1-year limited warranty service to the original owner of this product from the date of the purchase.

Any problems caused by the manufacturer's defect will be solved by free repair or replacing the whole product or necessary parts.

However, any problems caused by user's misuse, unapproved modification and disassembling, damage during use or shipping, or expected natural wear will not be covered by this program.

Please read the enclosed warranty card for more details. And Minoura strongly suggest to check out our web site regularly for the latest update.

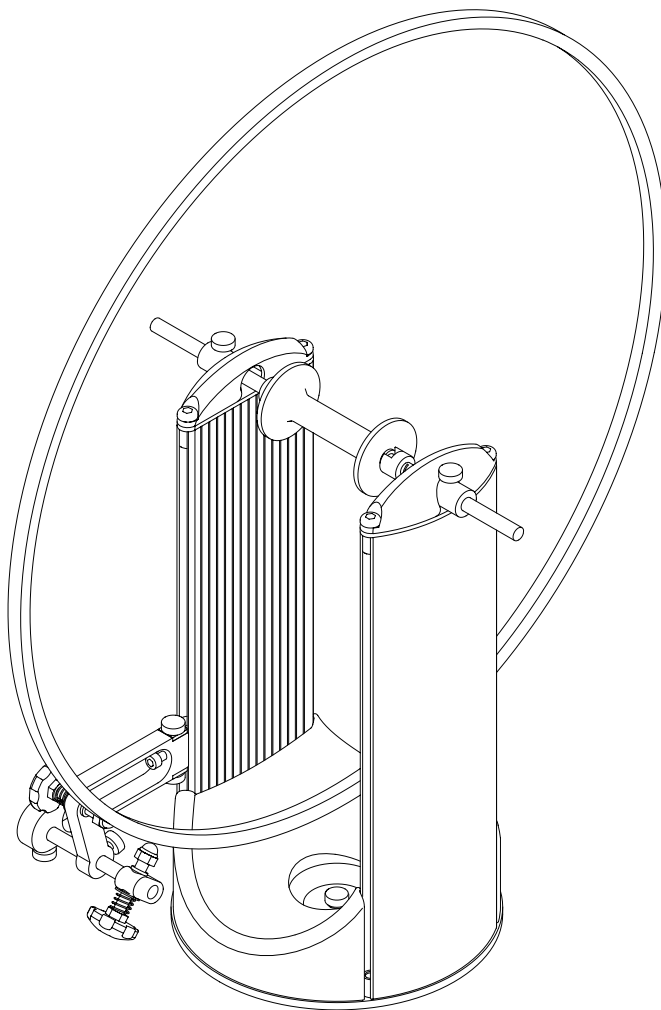
**Important Notes**

- FT-50 is a special tool for precisely maintaining the bicycle wheel. Do not use this product for any other purpose than instructed.
- Remove the quick release (Q/R) skewer from your wheel before use.
- We recommend removing the tire from the wheel before use.
- The max wheel hub width is 148mm. Remove the spring from the right side coupling axle when you mount a wide hub.
- Clamps on a standard 9mm Q/R using the side couplings. Depending on the axle lengths, some hub nut wheels may not be compatible with the FT-50.
- 12mm or 15mm thru axle type hubs are also compatible. Insert the supplied adapters in the hub hole for mounting.
- Please note that a small amount of rim surface scratches from the tips is normal. Especially on carbon or softer metal wheels.
- You don't need to spin the wheel so fast. Rotate slowly.
- The verticality of the pillar is the most important matter on FT-50. Do not apply any shock or damage to the pillars even while storing.
- The wheel is the most important component for your safety. Wheel truing job must be done at your own risk. Minoura is not be responsible to any result your job brings after using FT-50. If you are not so confident on this kind of job, stop and ask to a professional mechanic.
- Minoura is not responsible for any issues encountered with your wheels after using the product. Make sure you know what you're doing. If you have any doubts in your abilities, consult a professional. Minoura provides the tools for the job, but not any instruction on how to true the wheels.

**Contact**

*If you have question or problem on this product, please contact the shop where you originally purchase this product or the distributor in your country first. The distributor information can be found on our web site. Only when you cannot obtain enough service from them, you can contact Minoura directly.*

**MINOURA JAPAN**

(for ALL customers, including Canada)

1197-1 Godo, Anpachi, Gifu 503-2305 Japan

Fax +81-584-27-7505

minoura@minoura.jp / www.minoura.jp

**MINOURA NORTH AMERICAN TECH CENTER**

(for U.S. residents ONLY)

Mon - Fri, 9 am - 5 pm (PCT)

Phone 1-510-538-8599 / Fax 1-510-538-5899

support@minourausa.com

# Schematics

(NOTE: The metal knob bolts are all the same)

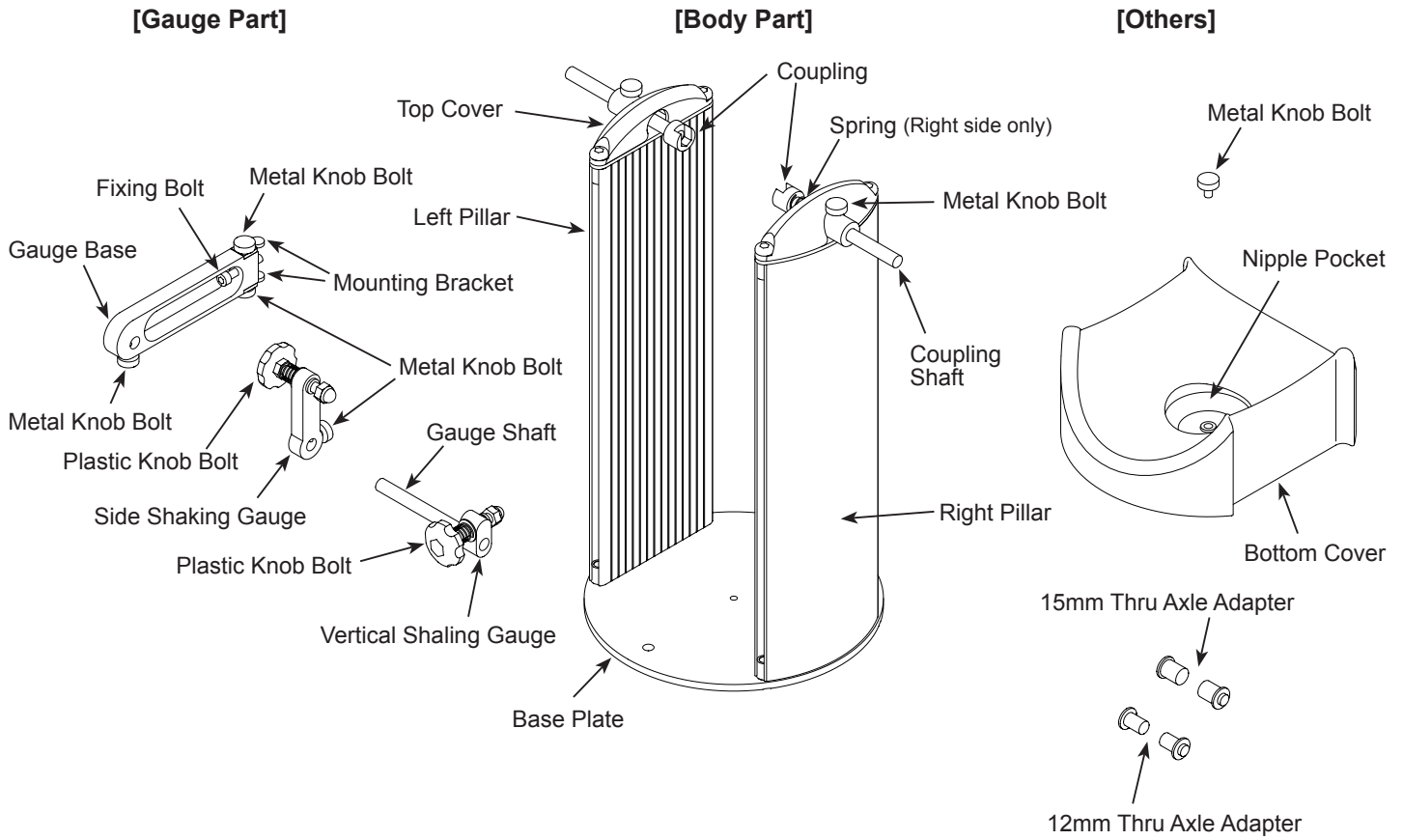

## How To Assemble

Required Tool : 5mm Hex Wrench

**1**

Take the stand body out and install the gauges on the pillar rail.

The gauges can be mounted on either side depending on your preference. On this example we're mounting from the left.

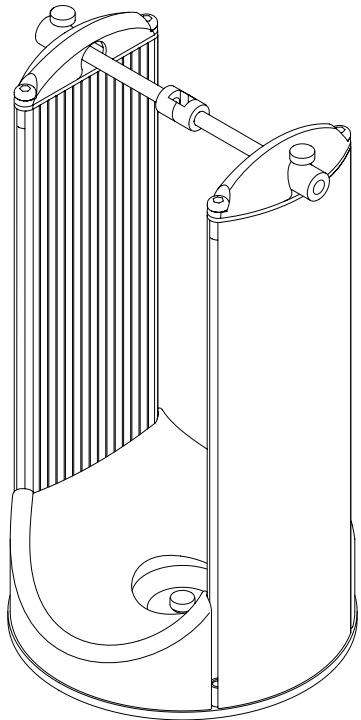

(Fig. A)

**2**

Loosen the metal knob bolt and pull up the Bottom Cover. You will see the disassembled gauges are stored under the cover.

When not using the FT-50 for extended periods, or during transportation, store the gauges and supplied thru axle adapters in the bottom of the unit to avoid loss.

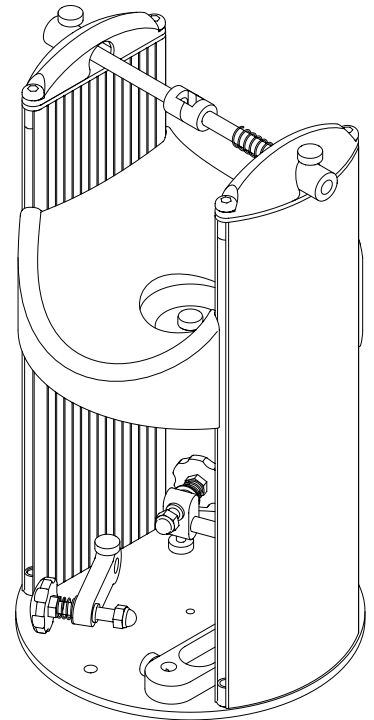

(Fig. B)

- 3** Install the gauges to the pillar rail.  
Remove the Mounting Brackets from the Gauge Base, and put it into the pillar rail.  
Flip the bracket vertical to insert, and flip horizontal back to hold.

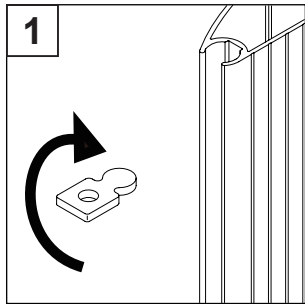

(Fig. C)

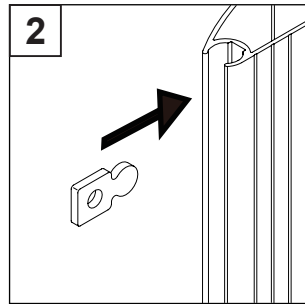

(Fig. D)

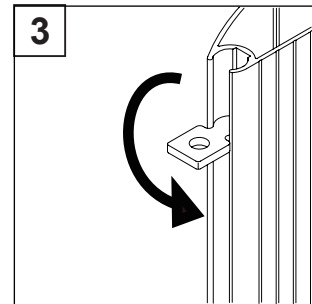

(Fig. E)

- 4** Sandwich the Gauge Base with the Mounting Brackets from top and bottom, and screw the metal knob bolts to mount. The Gauge Base will be held in position by screwing the inside bolt which pushes toward the wall.

You will change the gauge position later, so you don't need to tighten the bolt so firmly yet.

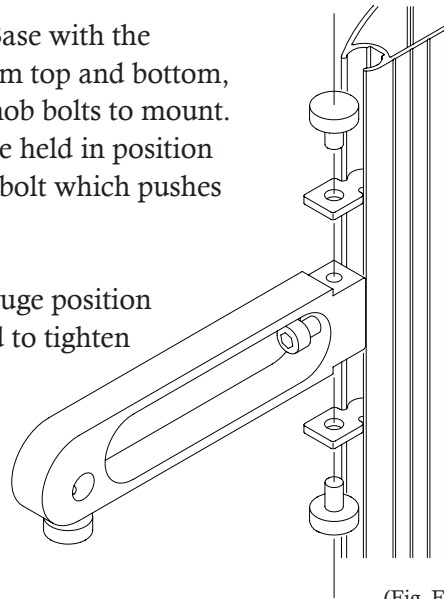

(Fig. F)



*There is some clearance between the bracket and the rail. That means the Gauge Base may not be fixed in exactly right angle to the pillar. Even if it's a little slanted, it's no problem.*



*Screwing the Fixing Bolt will pull the Gauge Base against the pillar and holds the Gauge Base solidly. However, tightening excessively will cause damage to the alloy rail tips and may cause the unit to not work properly. Do not over tighten the bolt.*

- 5** Insert the Side Shaking Gauge unit to the Gauge Shaft.

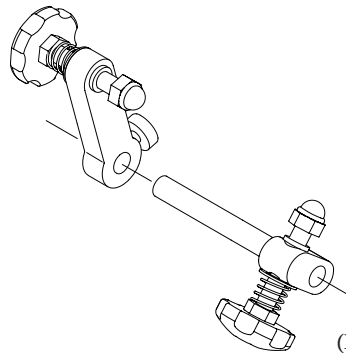

(Fig. G)

- 6** Then insert the shaft to the Gauge Base.

The gauge position will be adjusted later after mounting the exact wheel.

We suggest you to put a mark on the pillar to set the gauge in right position again easily.

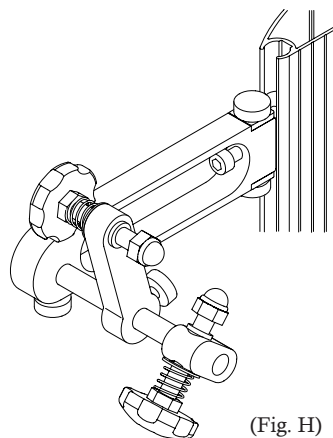

(Fig. H)

- 7** Assembly completed.

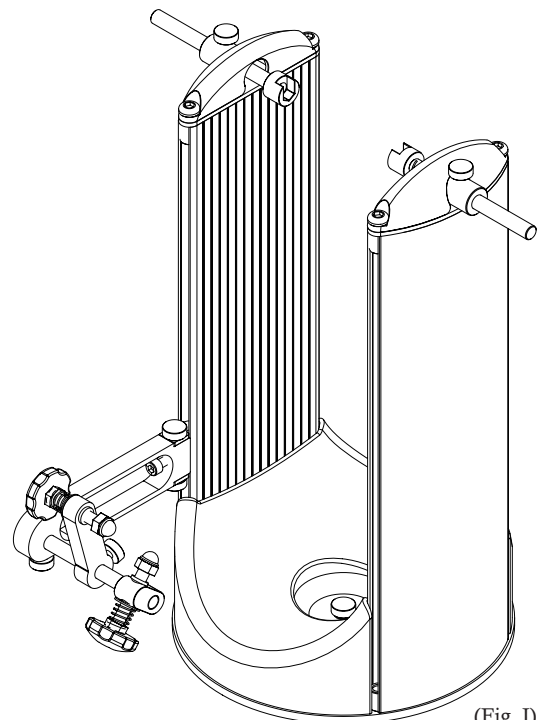

(Fig. I)

# How To Mount Wheel

## 9mm Quick Release Skewer Hub

## 12mm / 15mm Thru Axle Hub

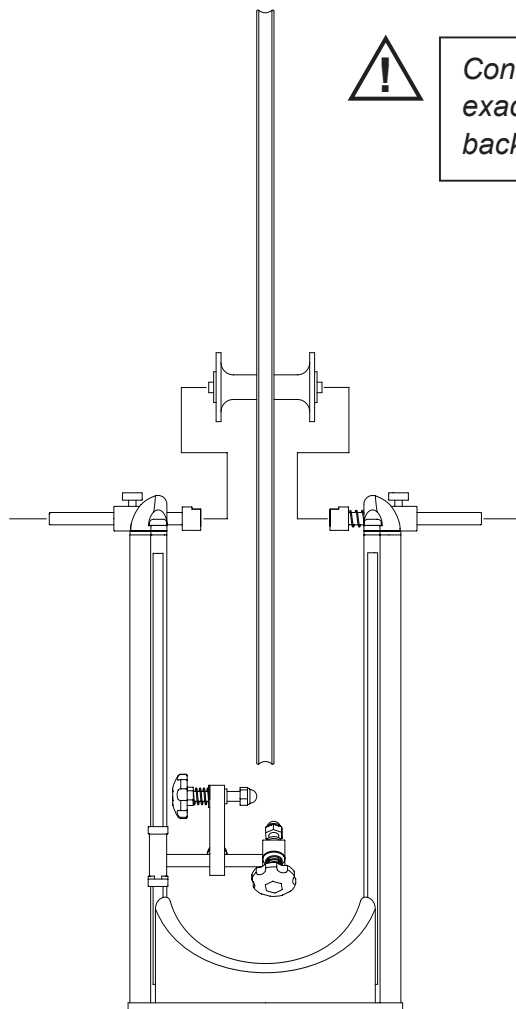

(Fig. J)



Confirm if the wheel is set exactly vertical without any backlash.

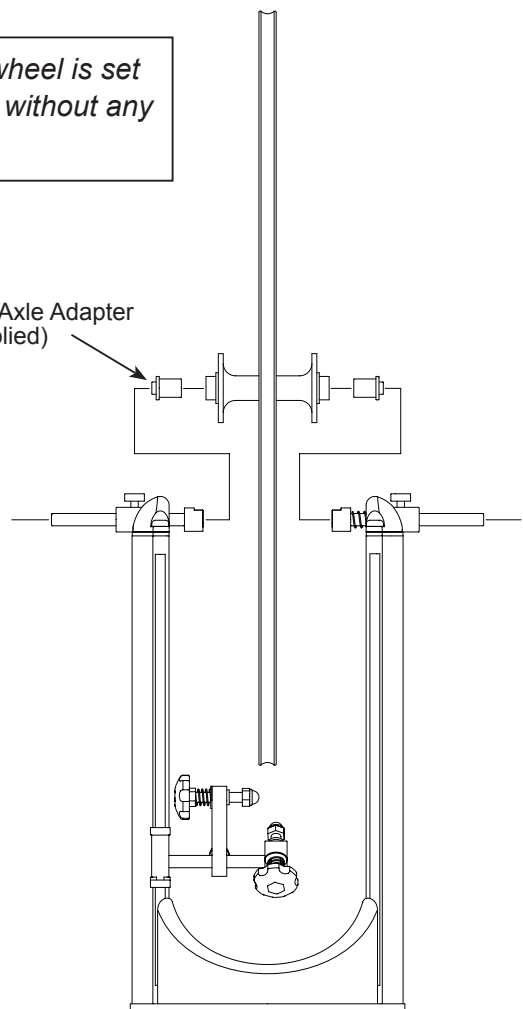

(Fig. K)

Twist the couplings as the open side faces top, and set the wheel as both side couplings clamp the hub. After clamping, tighten the metal knob bolt on the Top Cover to fix the position.

It's crucial that each hub end sits in the deepest position in the coupling that makes both right and left ends are set in the same height. This is critical in order to expect the correct result.

In case of thru axle hub, insert the supplied adapter in the hub hole before mounting.

### TIPS!

Make sure there is a spring in the right side coupling shaft. The spring helps push the hub towards the clamp for a better fit.

Temporarily hold the right side coupling as the spring is compressed, place the wheel, and set the left side coupling position. It means even if you loosen the metal knob bolt on the right side coupling, it still continues pushing the hub.

This is also good to know if the wheel is finished symmetric by flipping the wheel while retracting the right side coupling only (do not move the left side coupling).

It's almost the same as when you use a dishing tool.

## How To True The Wheel

Adjust both the side coupling shaft lengths equally in order to get the wheel in the center of the stand as closely as possible. Tighten the left side metal knob bolt firmly and tighten the right side knob bolt gently.

At first, loosen the metal knob bolt on the gauge base to set the Vertical Shaking Gauge to the rim edge as close as possible.

(Be sure you must remove the tire from the wheel for checking the vertical shaking)

Next, set the Horizontal Shaking Gauge to the rim side wall as close as possible.

Tighten every metal knob bolt to fix the positions.

You should check the horizontal shaking at the area where the brake shoe touches the rim. This area is resistant to scratching.

If your rim has a shallow wall like disc brake rims, it may be difficult to keep the rim from being scratched. Carefully choose the right areas for contact.

If the wheel has a tire and it has conflicted with the gauge or shaft, or the gauge tip cannot reach the rim, you need to remove the tire from the rim.

Rotate the wheel slowly, and try to listen for small scratching sound that the gauge touches the rim surface. If the contact is too hard, turn the plastic knob bolt counter-clockwise to retract the gauge.

Adjust the gauge position as it sometimes touches the rim, not often. As the job proceeds, you need to change the gauge position closer and closer, and in the final stage, you will see the gap between the gauge and the rim visually, and won't be listening for any sounds.

Here both side couplings are set in the correct position and the wheel is perfectly vertical.

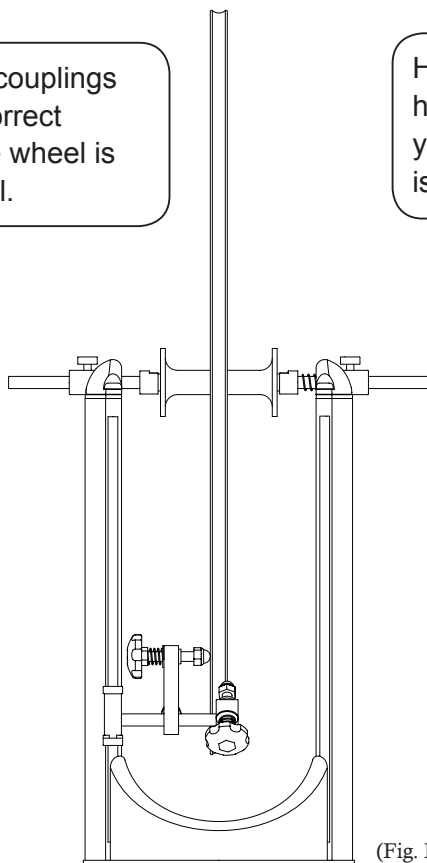

Here the hub end height is different and you can see the wheel is slanted.

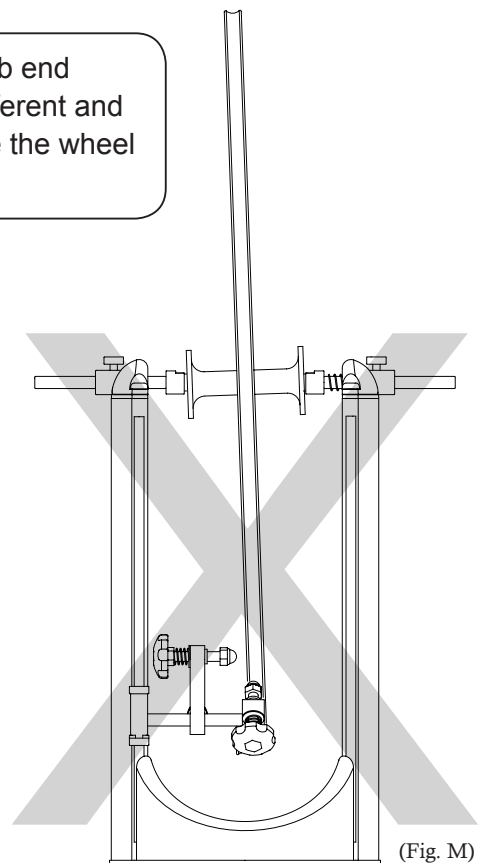

If you hear the scratching sound, it means the rim has been deformed toward the gauge.

Loosen or tighten the spoke nipples to adjust the rim shape to a perfect disc.

Continue checking the gap between the gauge and the rim carefully, and when there are no more sounds during rotations, the adjustment is complete.

In the side shaking adjustment, you should sometimes attach the Dishing Tool to know if the wheel is symmetric.

## Storing Gauges

To store the disassembled gauges under the Bottom Cover, place them as shown in the Fig. N.

Be sure the cover fully touches the Base Plate and you can tighten the metal knob bolt.

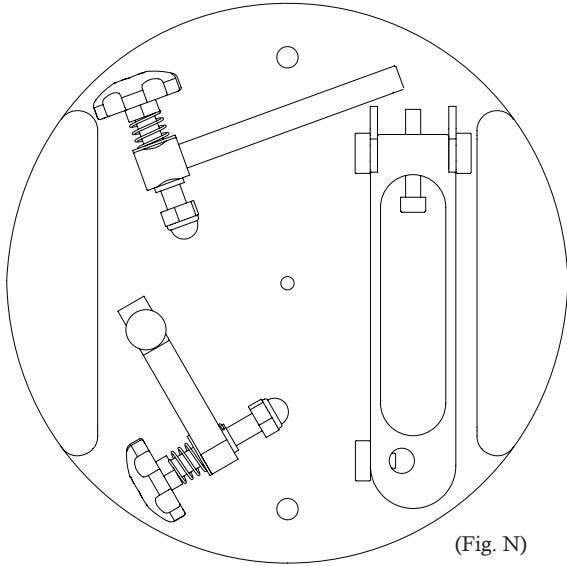

(Fig. N)

## Direct Mounting

You can fix the FT-50 to your work bench directly with M8 bolts if you need a more solid base.

Remove the Bottom Cover, and put the bolts into the two holes on the Base Plate.

The hole pitch is 180mm.

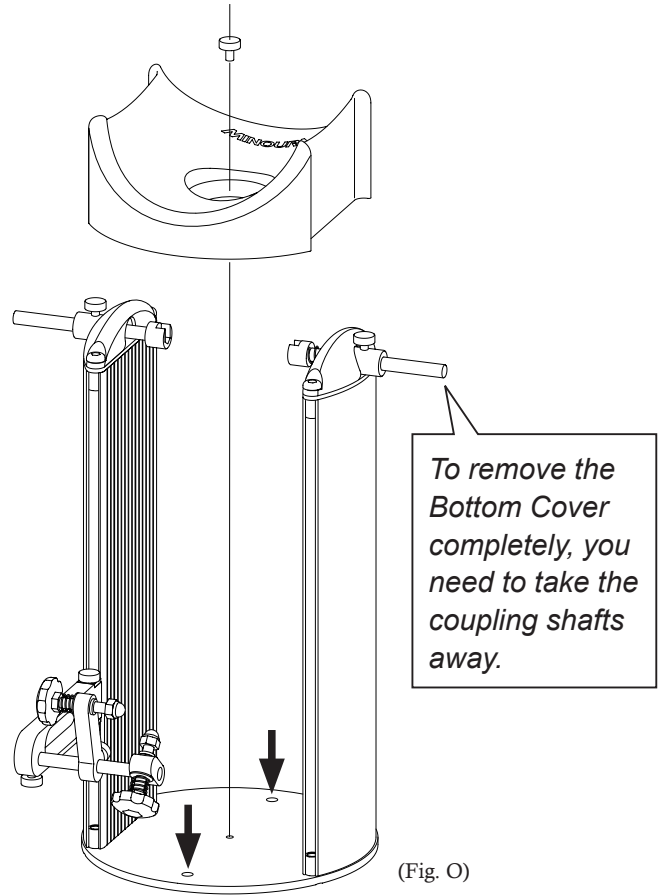

(Fig. O)