

The FT-50W is the wider version of the FT-50. This version offers tool storage and a handy carrying handle for easy transportation and storage.

Read this instruction manual carefully before use.
Keep this manual in hand while you use this product.

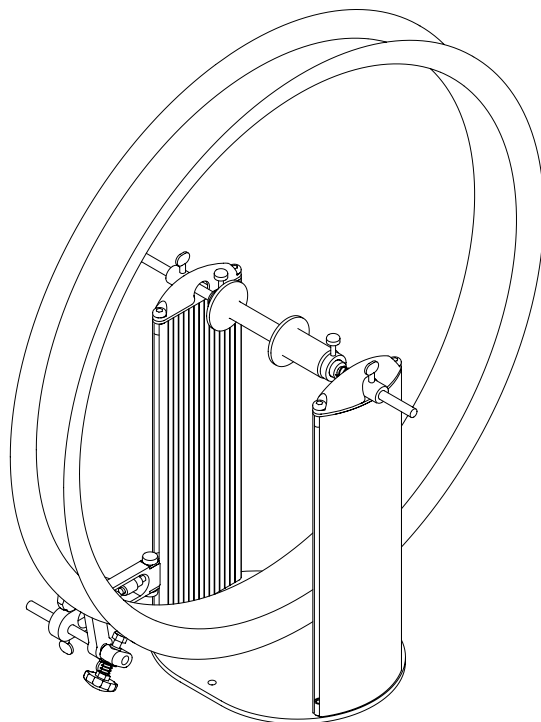
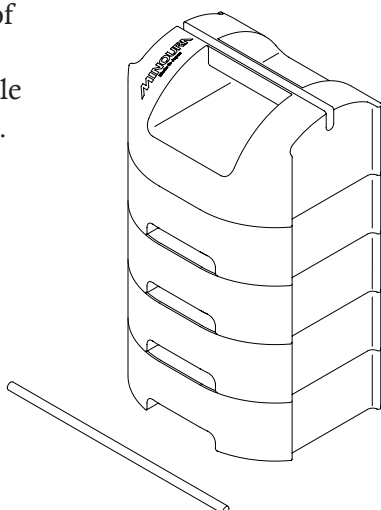

[In-Use Image with wide rim]

Warranty Period : 1 year

Minoura offers 1-year limited warranty service to the original owner of this product from the date of the purchase.

Any problems caused by the manufacturer's defect will be solved by free repair or replacing the whole product or necessary parts.

However, any problems caused by user's misuse, unapproved modification and disassembling, damage during use or shipping, or expected natural wear will not be covered by this program.

Please read the enclosed warranty card for more details. And Minoura strongly suggest to check out our web site regularly for the latest update.



Important Notes

- FT-50W is a special tool for precisely maintaining the bicycle wheel. Do not use this product for any other purpose than instructed.
- Remove the quick release (Q/R) skewer from your wheel before use.
- We recommend removing the tire from the wheel before use.
- The max wheel hub width is 210mm that covers most wide rims for fat bikes. Remove the spring from the right side coupling axle when you mount a wide hub.
- Clamps on a standard 9mm Q/R using the side couplings.
- 12mm or 15mm thru axle type hubs are also compatible. Insert the supplied adapters in the hub hole for mounting.
- Please note that a small amount of rim surface scratches from the tips is normal. Especially on carbon or softer metal wheels.
- Do not spin the wheel too fast. Rotate slowly.
- The verticality of the pillar is the most important matter on FT-50W. Do not apply any shock or damage to the pillars even while storing.
- Your wheels are critical to your riding safety. You assume all responsibility for working on your wheels. Minoura is not responsible for any issues that might arise from truing your wheels. If you have doubts, please take your wheels to a professional mechanic for service.
- Minoura is not responsible for any issues encountered with your wheels after using the product. Make sure you know what you're doing. If you have any doubts in your abilities, consult a professional. Minoura is supplying tool to do a job, but learning how to use this tool is your responsibility.

Contact

If you have question or problem on this product, please contact the shop where you originally purchase this product or the distributor in your country first. The distributor information can be found on our web site. Only when you cannot obtain enough service from them, you can contact Minoura directly.

MINOURA JAPAN

(for ALL customers, including Canada)

1197-1 Godo, Anpachi, Gifu 503-2305 Japan

Fax +81-584-27-7505

minoura@minoura.jp / www.minoura.jp

MINOURA NORTH AMERICAN TECH CENTER

(for U.S. residents ONLY)

Mon - Fri, 9 am - 5 pm (PCT)

Phone 1-510-538-8599 / Fax 1-510-538-5899

support@minourausa.com

Schematics

(In this manual, we are explaining with the gauge mounted on the left side. Of course, it can be set on the right side too.)

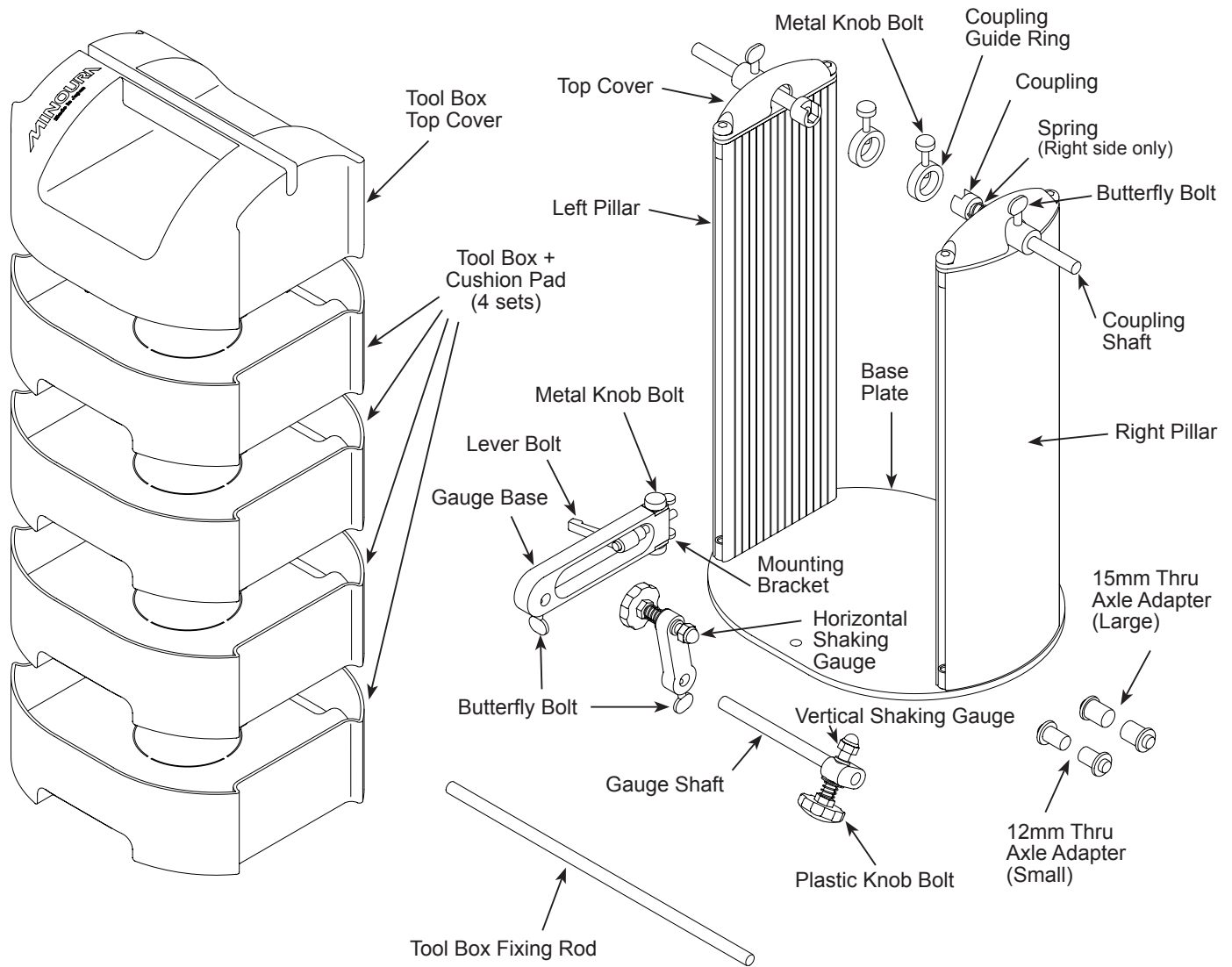

How To Assemble

Required Tool : 5mm Hex Wrench

- 1 Gently place the FT-50W on your work bench.

Loosen the butterfly bolts on top of the pillars, then the rod can be removed. (Fig. A)

If removal is difficult, we suggest using a pen to help push the rod through.

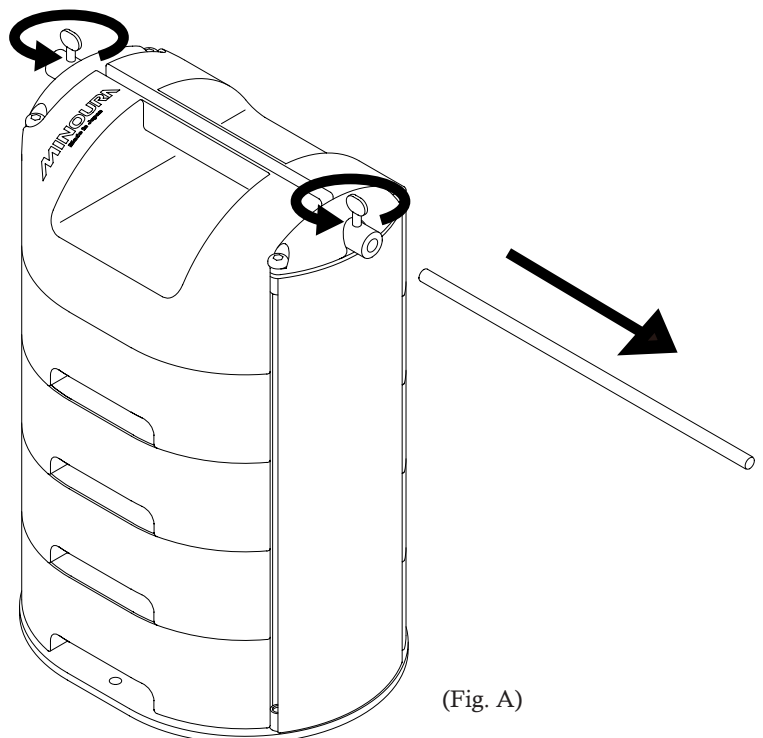

(Fig. A)

- 2** There is a total of four tool boxes stacked on top of each other. They can be removed by lifting them upward. (Fig. B)

You will see all necessary parts and adapters in the boxes.

Also you can use this space for storing your own parts and tools.



*The boxes are not connected.
You need to pull them out one by one, or grab the bottom box to lift all boxes up together.*



You must stack every box tightly as the bottom rib is completely hidden in the lower box, otherwise the fixing rod cannot be set in the last step.

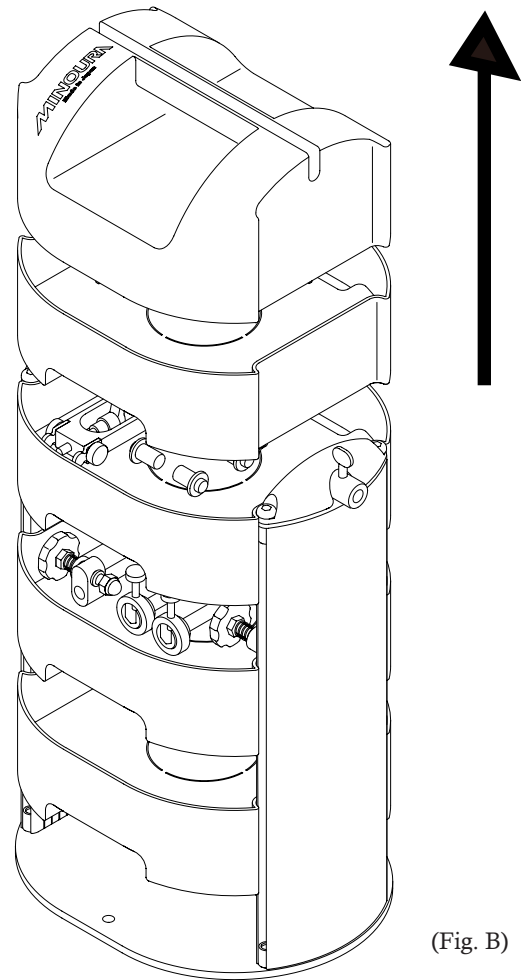

(Fig. B)

- 3** After removal of all boxes, you will install the gauges and coupling shafts onto the body.

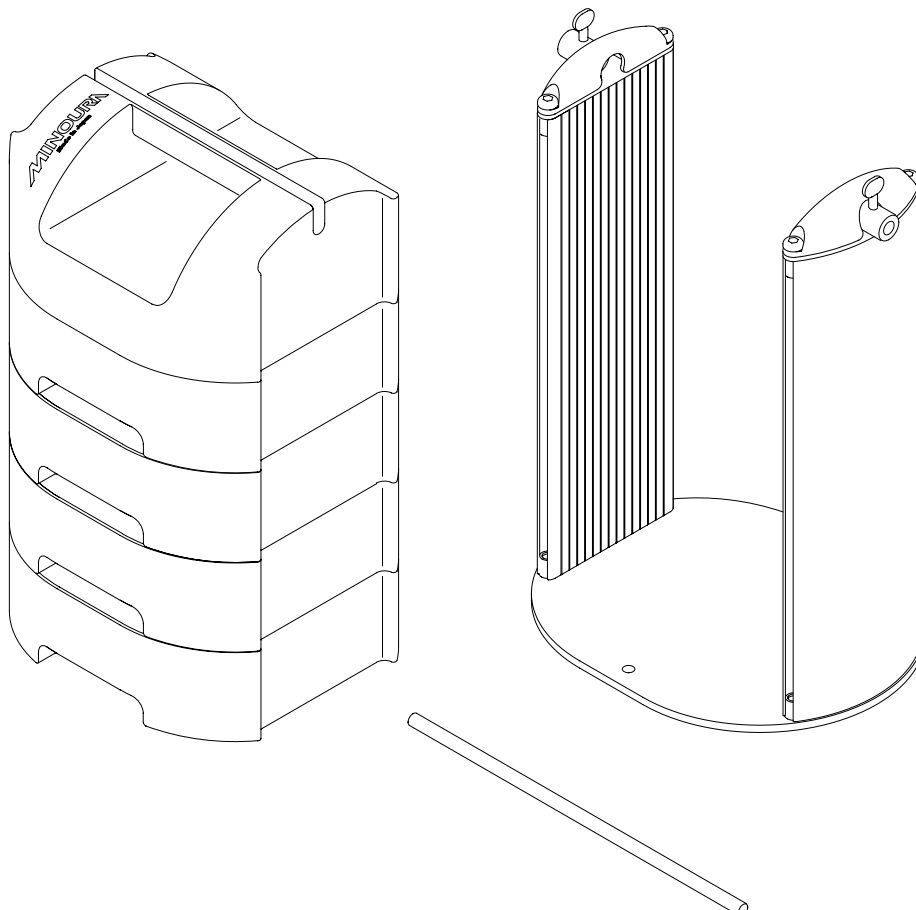

(Fig. C)

4

All 4 boxes are exactly the same.

To store a lubricant can or long tools such as a spanner or screwdriver, cut the center section of the cushion pad to make a hole, and put the tool into the hole.



Please note that it's difficult to repair the cushion if you modify it. Think carefully before cutting the cushion about your future needs.

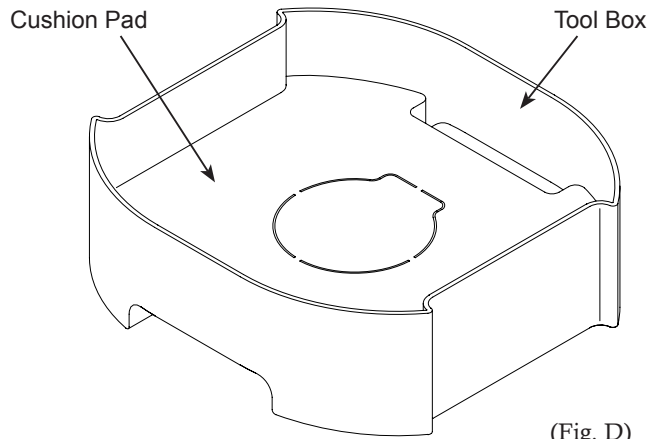

(Fig. D)

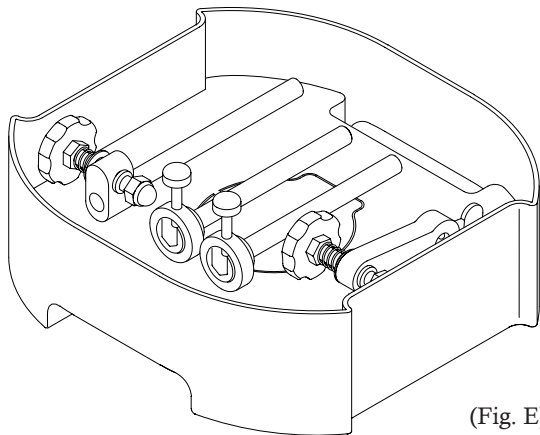

(Fig. E)

Coupling Shafts,
Vertical & Horizontal Shaking Gauge

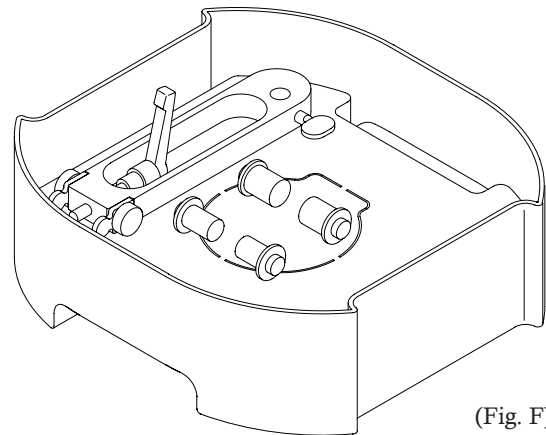

(Fig. F)

Gauge Base,
Thru Axle Adapters (12mm & 15mm)

5

Install the coupling shafts on top of the pillars, and set the coupling ring on each coupling.

The body is symmetric and the coupling shafts are exactly the same.

We are installing the spring on the right side coupling in this manual. Of course, setting on left side is no problem.

Insert a coupling shaft in the spring and set in the hole on the right side pillar. Tighten the butterfly bolt temporarily. (Fig. G)

On the left side, the coupling shaft doesn't have a spring.

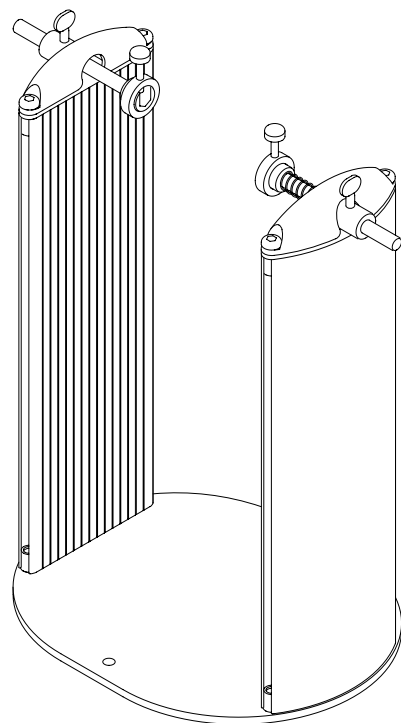

(Fig. G)

TIPS: About Lever Bolt

The lever bolt has a spring inside between the threaded bolt and the lever. You are free to set the lever at any angle as you want by pulling the lever while turning.

To fix the gauge base, turn the lever to tighten, pull the lever to get back to the previous angle, and repeat the steps to tighten more.

- 6** Install the gauges to the pillar rail.
Remove the mounting brackets from the gauge base, and put it into the pillar rail (Fig. H).
Flip the bracket vertical to insert (Fig. I), and flip horizontal back to hold (Fig. J).

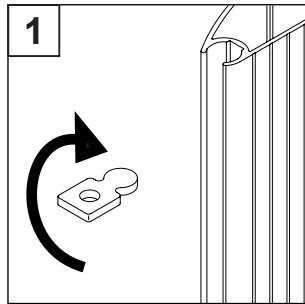

(Fig. H)

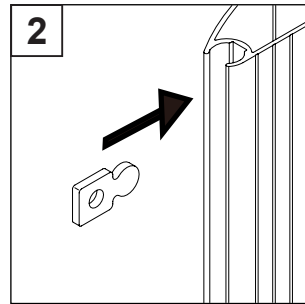

(Fig. I)

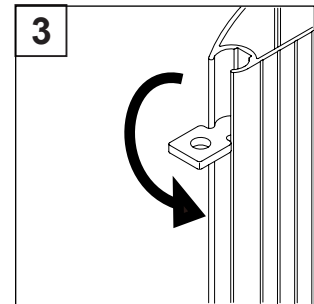

(Fig. J)

- 7** Sandwich the gauge base with the brackets from top and bottom, and screw the metal knob bolts to mount.
The gauge base will be held in position by screwing the inside lever bolt which pushes toward the wall.

You will change the gauge position later, so you don't need to tighten the lever bolt so firmly yet.

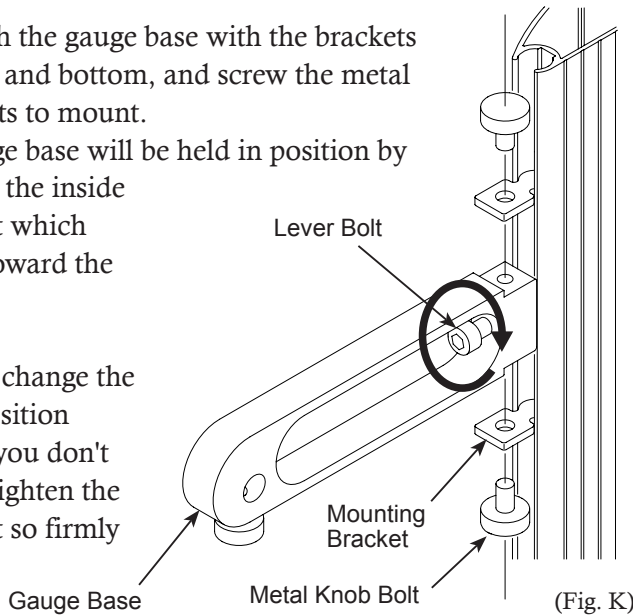

(Fig. K)



There is some clearance between the bracket and the rail. That means the gauge base may not be fixed in exactly the right angle to the pillar. Even if it's a little slanted, it's no problem.



Screwing the lever bolt will pull the gauge base against the pillar and holds the gauge base solidly. However, tightening excessively will cause damage to the alloy rail tips and may cause the unit to not work properly. Do not over tighten the bolt.

- 8** Insert the side shaking gauge unit to the gauge shaft. (Fig. L)

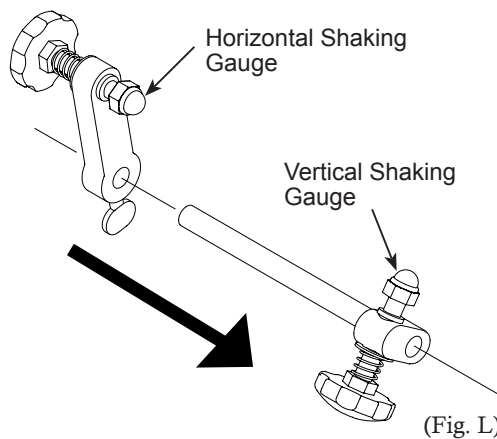

(Fig. L)

- 9** Then insert the shaft to the gauge base. (Fig. M)

The gauge position will be adjusted later after mounting the exact wheel.

We suggest you to put a mark on the pillar to set the gauge in right position again easily.

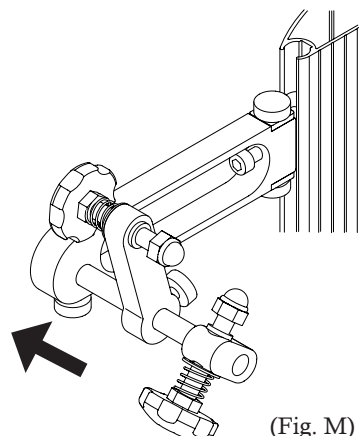

(Fig. M)

- 10** Assembly completed. (Fig. N)

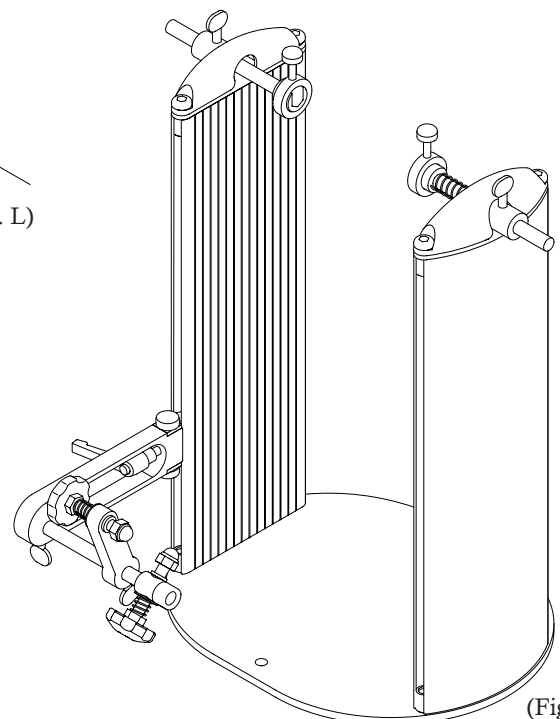

(Fig. N)

How To Mount Wheel

9mm Quick Release Skewer Hub

12mm / 15mm Thru Axle Hub

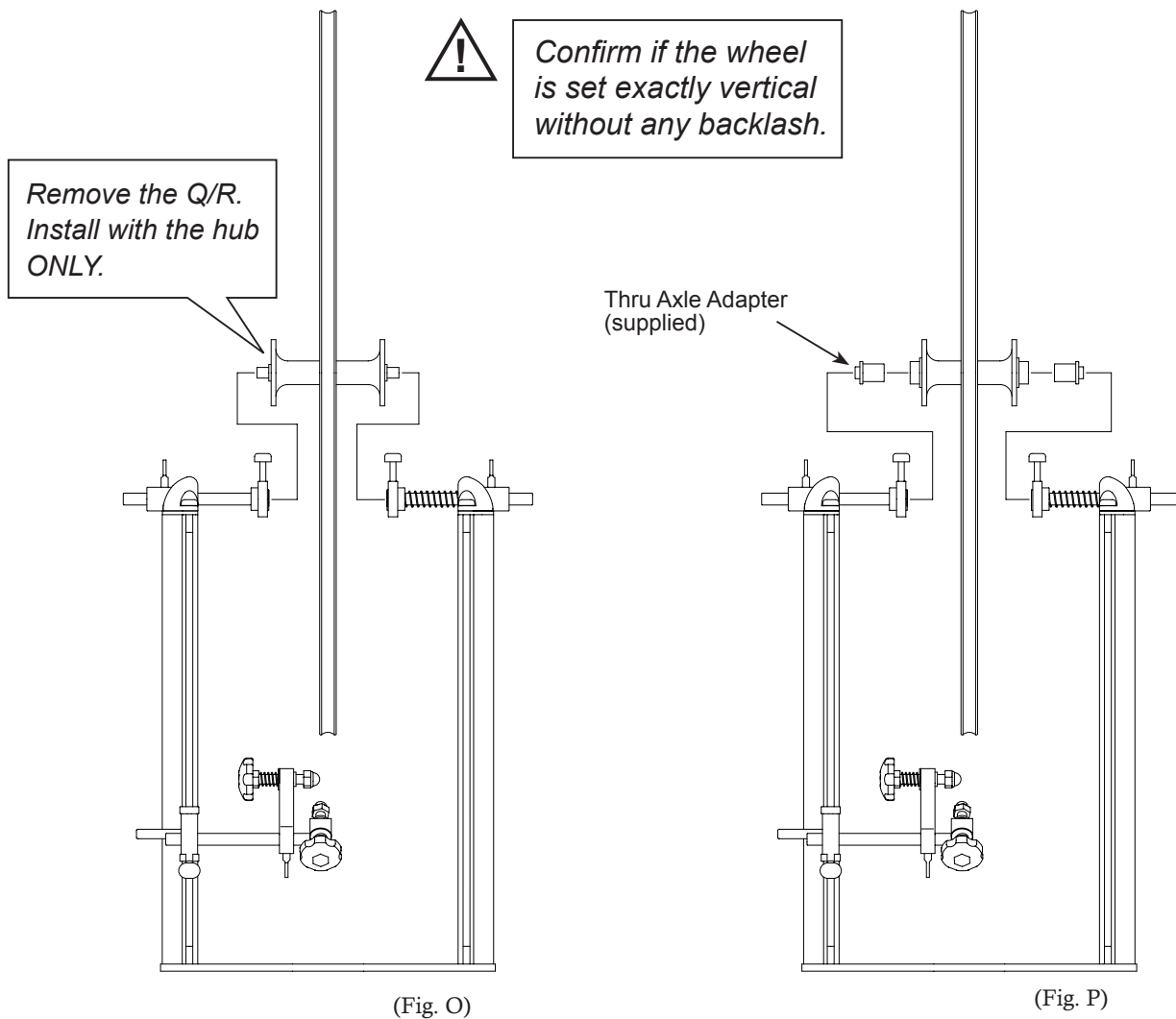

Twist the couplings as the open side faces top, and set the wheel as both side couplings clamp the hub. After clamping, tighten the butterfly bolt on the top cover to fix the position. (Fig. O)

It's crucial that each hub end sits in the deepest position in the coupling that makes both right and left ends are set in the same height. This is critical in order to expect the correct result. For this purpose, you should tighten the metal knob bolt on the coupling guide ring to push down and hold the hub axle.

In case of thru axle hub, insert the supplied adapter in the hub hole before mounting. (Fig. P)

TIPS!

Make sure there is a spring in the right side coupling shaft. The spring helps push the hub towards the clamp for a better fit.

Temporarily hold the right side coupling as the spring is compressed, place the wheel, and set the left side coupling position. This means even if you loosen the metal knob bolt on the right side coupling, it still continues pushing the hub.

This is also good to know if the wheel is finished symmetrically by flipping the wheel while retracting the right side coupling only (do not move the left side coupling).

It's almost the same as when you use a dishing tool.

How To True The Wheel

Adjust both the side coupling shaft lengths equally in order to get the wheel in the center of the stand as closely as possible. Tighten the left side butterfly bolt firmly and tighten the right side bolt gently.

At first, loosen the butterfly bolt on the gauge base to set the vertical shaking gauge to the rim edge as close as possible.

(Make sure you remove the tire from your wheel when checking vertical shaking.)

Next, set the horizontal shaking gauge as close as possible to the rim wall.

Tighten every butterfly bolt and metal knob bolt to fix the positions.

You should check the horizontal shaking at the area where the brake shoe touches the rim. This area is resistant to scratching.

If your rim has a shallow wall like disc brake rims, it may be difficult to keep the rim from being scratched. Carefully choose the right areas for contact.

If the wheel has a tire and it has contacted with the gauge or shaft, or the gauge tip cannot reach the rim, you need to remove the tire from the rim.

Rotate the wheel slowly, and try to listen for small scratching sounds that the gauge touches the rim surface.

If the contact is too hard, turn the plastic knob bolt counter-clockwise to retract the gauge.

Adjust the gauge position so it sometimes touches the rim, not often. As the job proceeds, you need to change the gauge position closer and closer, and in the final stage, you will see the gap between the gauge and the rim visually, and you won't hear any more scratching sounds.

Here both side couplings are set in the correct position and the wheel is perfectly vertical.

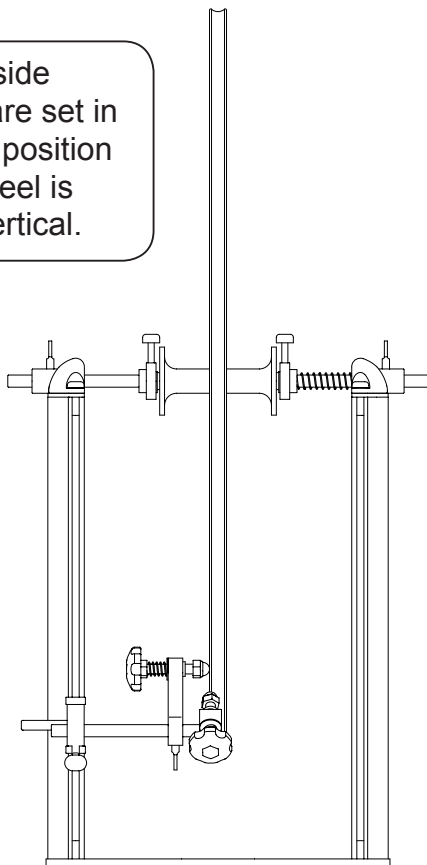

(Fig. Q)

Here the hub end height is different and you can see the wheel is slanted.

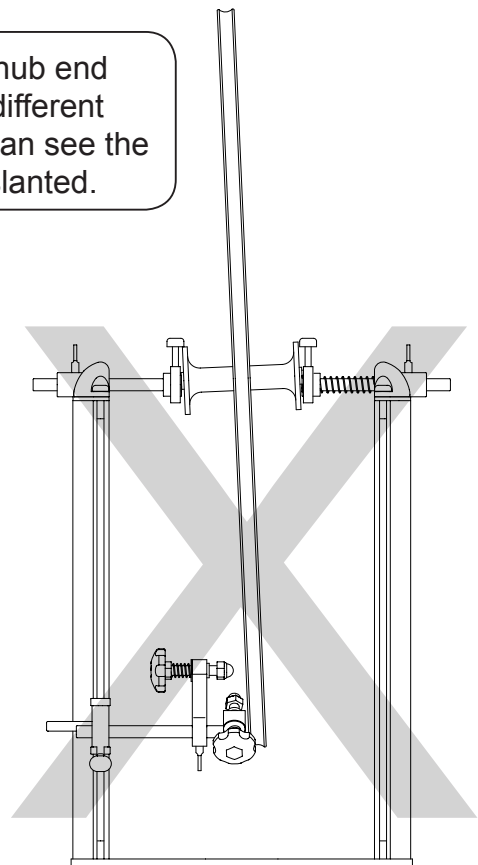

(Fig. R)

If you hear the scratching sound, it means the rim has been deformed toward the gauge. Loosen or tighten the spoke nipples to adjust the rim shape to a perfect disc. Continue checking the gap between the gauge and the rim carefully, and when there are no more sounds during rotations, the adjustment is complete.

In the side shaking adjustment, you should sometimes attach the Dishing Tool to know if the wheel is symmetric.

Direct Mounting

You can fix the FT-50W to your work bench directly with M8 bolts if you need a more solid base. (Fig. S)

The hole pitch is 190mm.

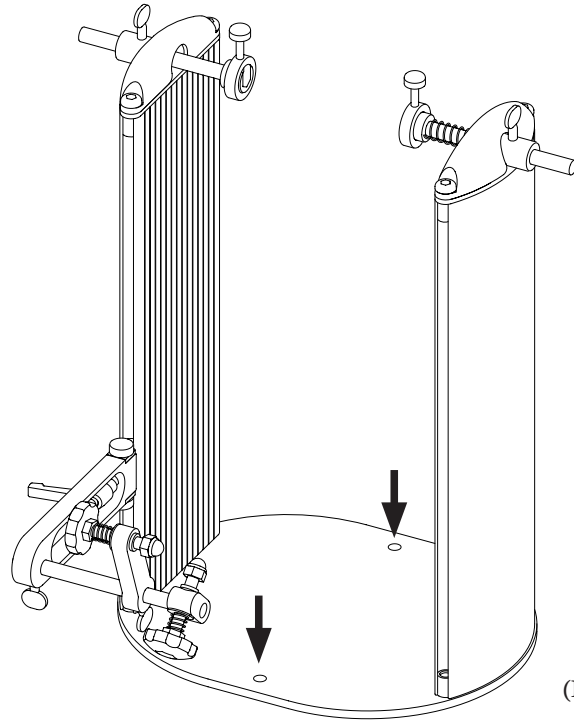

(Fig. S)

Optional Item

The vertical and horizontal shaking gauge can be upgraded to a micro meter. This allows you to distinguish the wheel shaking in the level of 0.1mm.